

**26/26**

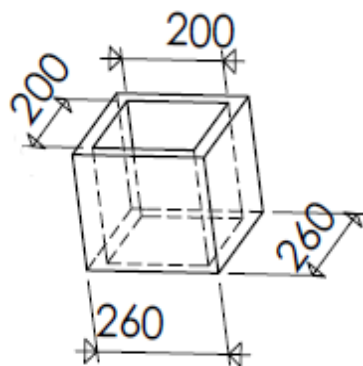

**30/30**

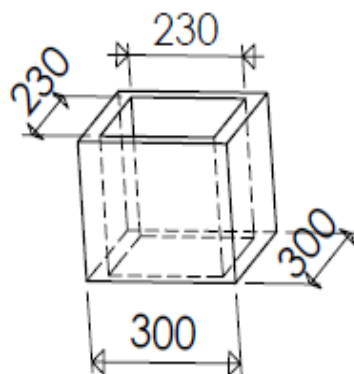

**33/33**

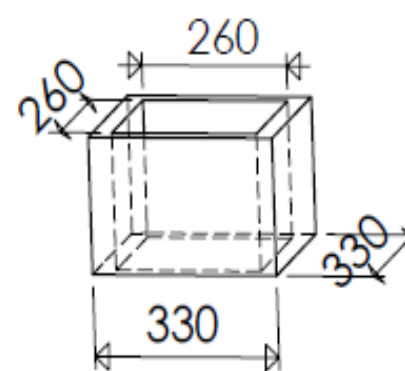

**26/40**

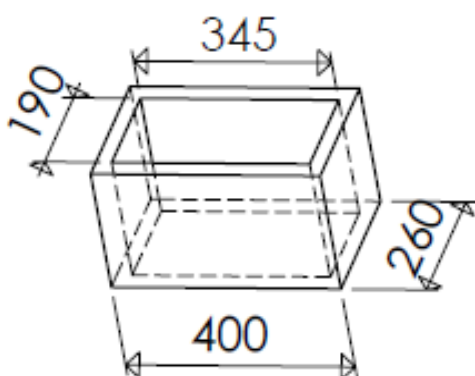

**26/40/2**

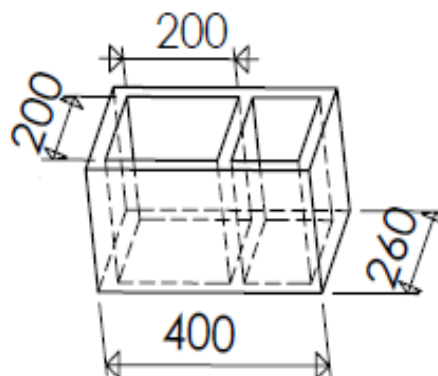

**26/40/3**

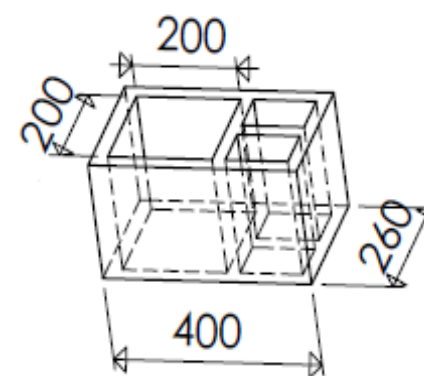

**30/48**

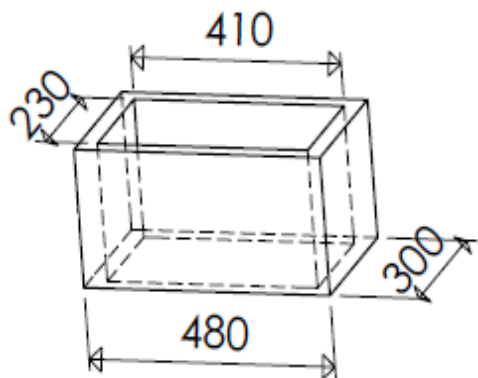

**30/50/2**

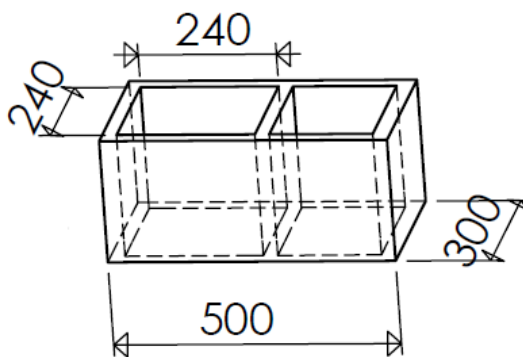

**30/50/3**

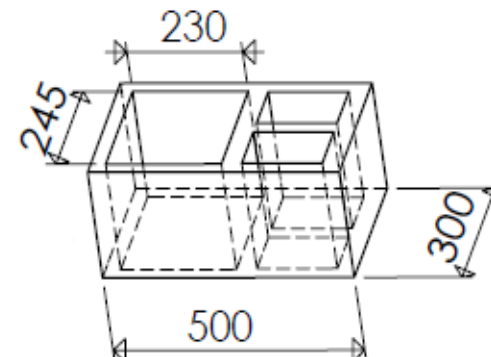

**30/60**

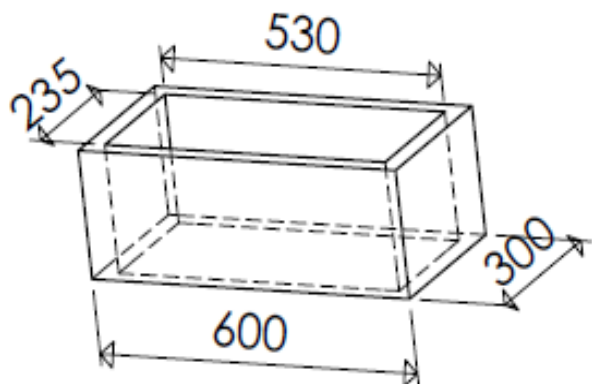

**30/60/2**

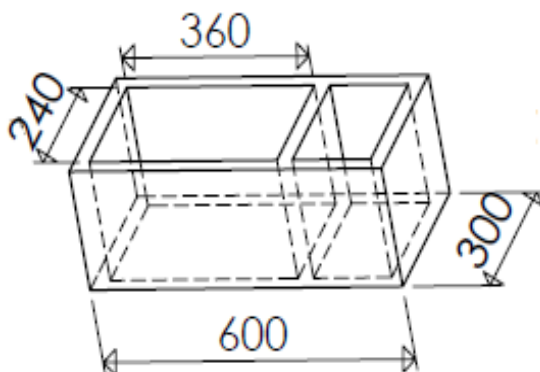

**30/60/3**

